

INFLUENCE OF PREHEATER LOSS IN REGENERATION EFFICIENCY ON THE SECONDARY CIRCUIT

Iulian Pavel NITA¹, Mircea ȚENESCU¹, Ilie PRISECARU², Daniel DUPLÉAC²

This paper presents the results of operating analyses in secondary circuit of Cernavoda NPP - Unit 2, in abnormal regimes, due to the failure of a feedwater preheater from the regenerative chain. Based on these analyses, operating solutions are proposed in order to minimize power losses from the normal regime. In this paper we developed a simplified method for calculating the operating parameters of the heat exchangers in abnormal regimes. Also this method allows quick detection of the abnormally operating heat exchanger.

Keywords: NPP operation, abnormal regimes, minimized losses, heat exchangers, plant efficiency

1. Introduction

In this paper one proposes optimizing the operating procedures in event of preheater unavailability. Current procedure, in case of isolation of a preheater, requires a reactor power step back of 10% of the rated value, what reduces the generated electric power by about 70 MWe.

The paper analyzes the operating regimes and thermal-hydraulic and economical implications which can occur in case of reactor power maintained at its rated value.

One considers the process and instrumentation diagram a CANDU 6 Unit of Cernavoda NPP (figure 1). The upstream and downstream limits of the analysis are main condenser nozzles and steam generator nozzles, respectively.

The simulation used as input data the result from stationary hydraulic analyses performed for Main Condensate System and FeedWater System. These analyses were based on the computational code PIPENET.

In order to model and simulate the thermal hydraulics of regenerative chain we used the computational code MMS (figure 2 and figure 3).

There were examined the following possible transient regimes:

1. Normal operating regime, used for model calibration;
2. The regime of preheater by-pass, with reactor power stepped back to 90% of rated power (RP) for the cases: by-pass of a LP1; by-pass of the a LP2 and LP3 bank ; by-pass of a HP 5
3. The regime of by-pass of a preheater with reactor power maintained to 100% of RP for the cases: by-pass of a LP1; by-pass o a LP2 and LP3 bank ; by-pass of a HP 5

The results obtained allowed the determination of electric power value produced by the power plant in regimes 2 and 3. In case of operating the reactor at 100% RP when a LP1 is by-passed, the Unit power is reduced by 2%; when a LP2 and LP3 bank is by-passed and when a HP5 is by-passed the Unit power is reduced by 4%. When the rector is stepped back to 90% RP the Unit power reduces by 11-12%. It leads us to idea of a new operating procedure with the reactor power maintained to RP, in event of unavailability of any preheater. It will result in a gain of the turbo-generator group power of at least 8%, that is about 50MW.

¹ Eng., Center of Engineering and Technology for Nuclear Projects

² Prof., Power Plant Engineering Department, Politehnica University of Bucharest, Romania

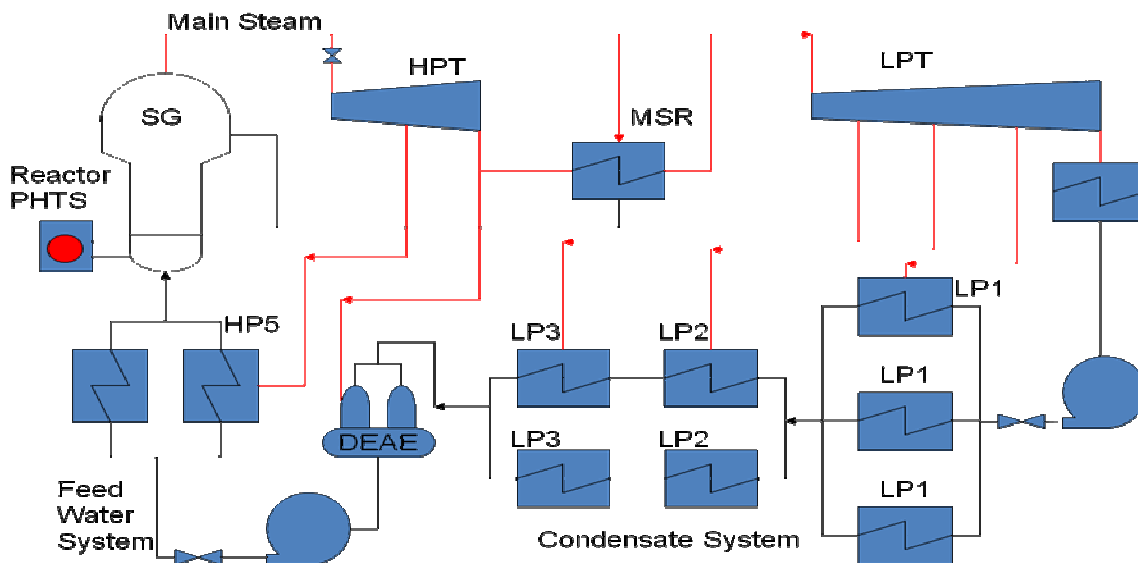

Figure 1. Process diagram of regenerative system: SG - Steam Generator; HP - High Pressure Heater; LP - Low pressure heater; MSR - Moisture Separator reheater; HPT - High pressure turbine); LPT - Light Pressure turbine

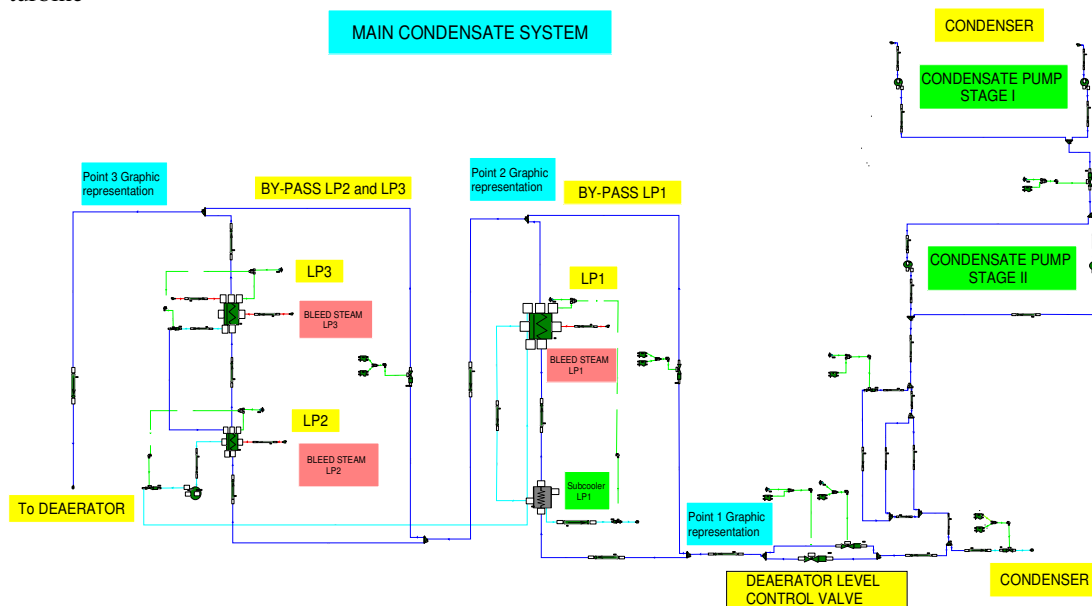

Figure 2 Computational diagram of the Condensate System

Influence Of Preheater Loss In Regeneration Efficiency On The Secondary Circuit

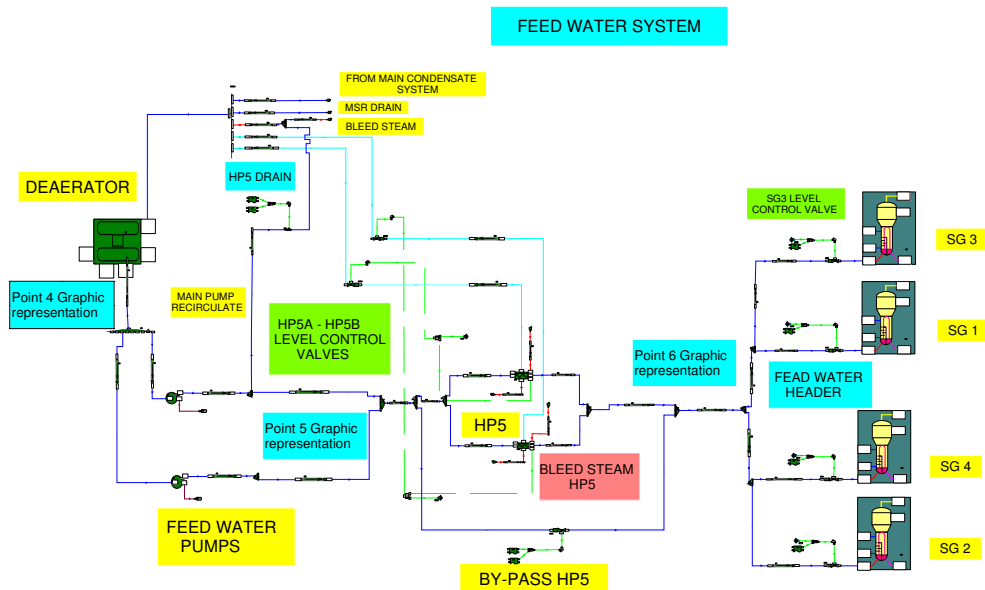

Figure 3 Computational diagram of the Feedwater System

2. Simulating and modeling of transient regimes of regenerative preheating system

Regenerative chain of a NPP (nuclear power plant) includes low pressure reheaters (LP), high pressure reheaters, (HP) a deaerator (D), feed water pumps (PA), and pipes (see figure 1).

Regenerative preheating modeling was done modular. Each type of equipment is modeled separately. One interconnects modules by transferring the output values in a way become input into values for the next module. In the whole model there were introduced modules for preheaters, valves and automation parts. Computational diagram of the simulation of the regenerative chain using MMS is shown in Figure 2 and 3.

Mathematical models underlying the complete module simulation are described in [3] and were confirmed and applied in simulation work for Cernavoda NPP systems [4, 5.7]

One pursued the development parameters of the preheating circuit regenerative procedures referred to. In the analysis have sought answers to 2 questions:

- The system's ability to maintain power reactor at face value?;
- Development of system parameters (pressure, temperature, etc.) Endanger the safe operation of the plant?

In the review one considered all existing automation and functional facility that is level regulators of each preheater (LP1, LP2, LP3, HP5 and deaerator) and flow regulators of steam generators. One considered for the changes of field of the plant, that the most important parameters are flow rate and fluid temperature throughout the plant.

MMS computational code was used for transient operating in order to obtain outcomes of the system and new stationary regimes that occur after system stabilization, thereby determining the operating parameters. They were presented in detail in ref. [10].

This work aims to present a simplified calculation method of heat exchanger. The method is illustrated on a feedwater preheater, i.e. HP5.

3. Simplified calculation of a regenerative preheater

The normal operation of the installation of regenerative preheating water supply from thermal power stations and nuclear power at part load turbo-generators group is a constant concern of the designers and operating personnel [1,5,7,8].

Feedwater preheater behavior can be determined if one known in detail heat transfer process that occurs in these devices, when the load of turbo-generator is changing.

Complete calculations of heat balance and heat transfer arrangements were made for 100%, 80%, 60% and 40% of the flow rate of steam generator - schemes presented in HB-GE and recalculated in [11.12].

One performed the exact calculation of heat transfer using MATHCAD program. The results of this calculation were summarized in two diagrams and system of mathematical equations used in computer processing.

Using this simplified method of calculating the behavior of regenerative preheater abnormal regimes, with a minimum of input data (load power in the 40-100% RP and temperature of input water preheater) may cause exit temperatures, temperature, pressure device in the condensation and heat load.

This simplified method has the next advantages: quickness and calculation handiness; it can be done during operation, in order to evaluate the state of the heater through comparing data from design with exploitation; very good evaluation comparing with exact solution.

Exact calculation was performed for the four base regimes that define the curves from diagrams namely regimes 40%, 60%, 80%, and 100% MCR (main continuous rate) for flows and pressures at turbine bleed that HP5 preheaters.

Convection heat transfer coefficients were calculated separately for each of the working areas of equipment HP5 namely the condensation: the steam condensing zone: the water supply; subcooled and condensed area: the condensed steam; subcooled area condensed: the water supply.

For the four areas above were used the following relations for convection calculation:

$$a) \quad \alpha = 0.95 \cdot \left[\lambda^2 \rho^2 \frac{g}{G'_s \cdot \eta} \right]^{\frac{1}{3}} \cdot \frac{1}{N^{0.1666}} \quad (1)$$

$$b) \quad \alpha = \lambda^* \frac{Nu}{d_i}; \quad Nu = 0.021 \cdot Re^{0.8} \cdot Pr_{fl}^{0.43} \cdot c \quad (2)$$

$$c) \quad \alpha = \lambda^* \frac{Nu}{d_i}; \quad Nu = 0.021 \cdot Re^{0.8} \cdot Pr_{fl}^{0.43} \cdot c \quad (3)$$

$$d) \quad \alpha = \lambda^* \frac{Nu}{d_e}; \quad Nu = 0.021 \cdot Re^{0.6} \cdot Pr_{fl}^{0.33} \cdot \left(\frac{\eta_{fl}}{\eta_p} \right)^{0.14} \quad (4)$$

The values of global heat transfer coefficients for the 3 areas indicated above on are shown in Table 1:

Influence Of Preheater Loss In Regeneration Efficiency On The Secondary Circuit

Table 1. The values of global heat transfer coefficients for the three area

HP5	Regime			
heat transfer coefficient	100%	80%	60%	40%
condensing area	3113.7	3022.9	2861.1	2581.9
subcool area	2226	1946.9	1642.6	1308.6

In figure 4 one presented the heat flux of a HP 5 versus turbo aggregate load. Figure 4 was obtained using terminal temperature HP 5 (see figure 5 and 6), determined with simplified procedure.

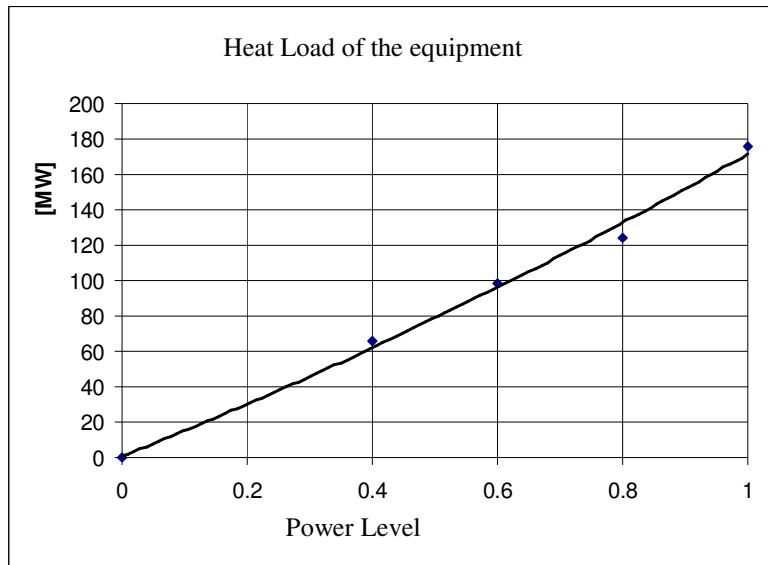

Figure 4. Heat load of equipment HP5 according to plant load

For user-friendly computer codes in the analytical correlation for heat by power load is:

$$Q(x) = 29,296 \cdot x^2 + 141,84 \cdot x + 0.688 \quad [MW_t] \quad (5)$$

Where x is the percentage of power.

$$DT(x) = 5,2083 \cdot x^4 - 6,0417 \cdot x^3 + 4,0417 \cdot x^2 - 0,4083 \cdot x + 0.6788 \quad [^\circ C] \quad (6)$$

$$dT(x) = 5,86 \cdot x^2 - 0,4764 \cdot x + 0.051 \quad [^\circ C] \quad (7)$$

Where x is the percentage of power.

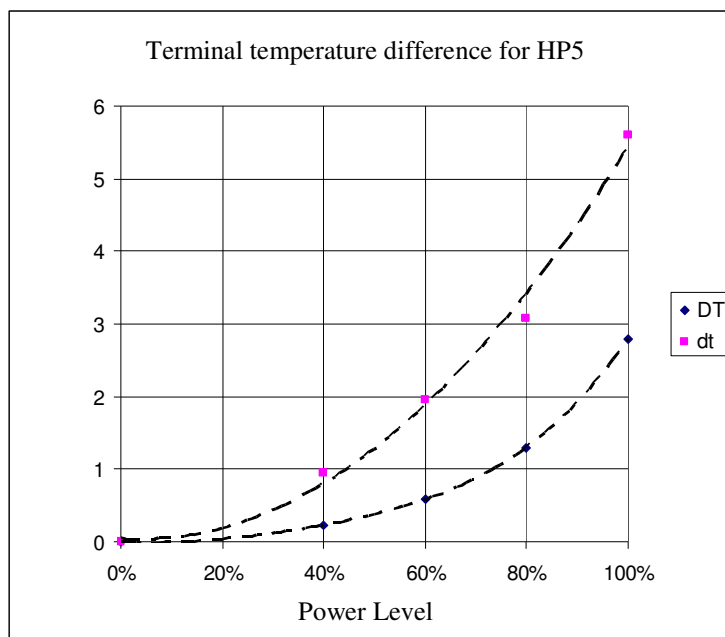

Figure 5. Terminal temperature difference DT and dt for HP5 equipment according to the power load

Once the details made above were done, one can proceed to establish parameters and equipment operators working in particular:

- bleeding steam at outlet steam turbine
- Feedwater

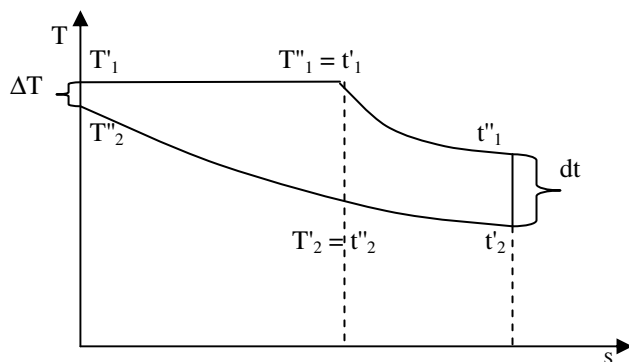

Figure 6. Temperature final differences heat exchanger equipment

Known variables:

- a) Q - heat load of the equipment from figure 5
- b) t'_2 - feedwater temperature upstream of HP5
- c) g_{apa} = required feedwater

Influence Of Preheater Loss In Regeneration Efficiency On The Secondary Circuit

Based on known input data, one could determine output temperature without appealing to transcendental equations of heat transfer:

$$T''_2 = \frac{Q}{g_{apa} \cdot C_{pm}} + t'_2 \quad [^{\circ}\text{C}] \quad (8)$$

Once determined the size T''_2 and known as t'_2 resulting:

$$T'_1 = T''_2 + Dt \quad [^{\circ}\text{C}] \quad (9)$$

$$t''_1 = t'_2 + dt \quad [^{\circ}\text{C}] \quad (10)$$

Using diagram from figure 5 or analytical relations [6] and [7] for partial load which would calculate.

Having the value of T'_1 that represents the steam condensation temperature (saturation temperature) we can determine operating pressure from condensing zone.

The method indicated above was used for all regenerative preheater system. Having appropriate diagrams available, it will provide equipment characteristics used to simplify calculations of energy balance throughout the regenerative circuit.

4. The electric energy efficiency of secondary circuit

The computation of plant efficiency has on the base heat balance relations written on complete secondary circuit of the plant. The computation was based on solving simultaneous equations of heat balance on all heat regenerative heaters from secondary circuit of the power plant. Computational relations used for each heat exchanger were presented in previous paragraph.

Energy balance equations were written for each of the three unavailability's LP1, LP2-LP3 and HP5, for 96-97-98% of nominal load. The results were compared with known values and we selected the closest ones.

For each form three cases we had three abnormal regimes:

- α) unavailability of a LP1;
- β) unavailability of a bank of LP2-LP3;
- γ) unavailability of a LP5.

Combining the computation for flow rates corresponding to 96-97-98% from nominal power with the three cases of abnormal operation we obtained 3 x 3 - 9 computational cases.

Table 1 Stationary regime calculation

Initial	α	β	γ
96%	0.9797	0.965	0.957
97%	0.9811	0.9732	0.955
98%	0.9816	0.9854	0.955

Comparing the results we obtain 3 pairs of values:

$$(\alpha - 98\%) \rightarrow 98.16\%; (\beta - 96\%) \rightarrow 96.50\%; (\gamma - 96\%) \rightarrow 95.70\%$$

From these data we can conclude that loss of one LP1 affects not so much the global efficiency of secondary circuit. The unavailability of a HP5 of a bank of LP2 - LP3 leads to a loss of 4% of electrical power generated with the reactor power, the loss been twice as big as in case of unavailability of LP1.

5. Conclusions

In this paper one presented a simplified method used for fulfillment of a thermal calculation if a heat exchanger for abnormal operating regimes. This method was applied to the complete regenerative chain form NPP Cernavoda in order to obtain the values of energy efficiency for regime of unavailability of a preheater. One considered a parametrical analyze function of level of reactor power after initiating event: at first one considered he reactor power lowered to 90% of PN (conform to actual operating procedure) and a second analyze were one considered he reactor power maintained to 100% (proposed operating procedure)

Following the computation made in case of unavailability of a preheater, one observed that if the reactor power is maintain to 100% of nominal power, the maximum power surge of the plant its of about 4% (in case of HP5 or LP2/3 unavailability) comparing to 12% in case of reactor power step back to 90% from its nominal power. The difference between the two cases is obvious and it's on the side of the case of maintaining the reactor power. 8% recovery from nominal power represents a very important loss for a nuclear plant, in our case of about 50MW.

This method permits that starting from nominal regime of the heat transfer equipment to determine its fouling rate or its malfunction. Practical, in real time an operator can determine the installation operating condition without require a stop of the installation.

As result of paper one concludes that reducing the power of the reactor from 100% to 90% of nominal power in event of unavailability of preheater is not justified either form concerns from economical or safety operation point of view.

6. Bibliography

1. M. POP, A. LECA, F. CHIRIAC, Procese de transfer de căldură și masă în instalațiile industriale, Ed. Tehnica - 1982
2. 40010-A109-HB - HEAT BALANCE DURING By-pass of one LP1 (90% Load)
3. Prisecaru, Ilie MODELAREA PROCESELOR DINAMICE DIN CENTRALELE CLASICE ȘI NUCLEARE. Editura Proxima, Bucuresti, 2009
4. Ilie Prisecaru, D. Dupleac, Nita Iulian – " Water Hammer in Nuclear Installations Case Study in Feed WaterSystem" – Proceedings of international conference ESMc'2008
5. Bigu, M.; Nita, I.; Prisecaru, Ilie; Dupleac, D. Modelling of Preheated Regenerative Chain from NPP Cernavoda using MMS Calculation Code, International Symposium on Nuclear Energy SIEN 2005 p. S1.4.1-S1.4.13, Bucuresti (Romania) 23-27 Oct 2005
6. Prisecaru Ilie, Dupleac, Daniel. CANDU Saturated Steam Turbine Modeling using COMPGEN for MMS package. În: vol.: ESMc'2005
7. Nita Iulian; Gheorghiu, Mihai; Prisecaru, Ilie; Dupleac, Daniel; Simulating the transient regime for main condensate system at Cernavoda NPP. În: vol.: International Conference on Energy-Environment, CIEM 2005 Bucharest.
8. Nita, Iulian; Prisecaru, Ilie; Dupleac, Daniel. Cernavoda NPP feedwater system transient analysis using MMS package. SIEN 2003
9. Prisecaru, I.; Dupleac, Daniel; Constantinescu, Adrian Cornel ; Modelling and simulating the transitory regimes in NPP using the MMS package programs; SIEN 2003,
10. Nita, I.; Prisecaru, Ilie; Dupleac - Modelling and Simulation of the CANDU 6 Feedwater System Behaviour- ESM 2009
11. 40010-A109-HB - HEAT BALANCE DURING By-pass of one LP1 (90% Load)
12. 40010-A110-HB - HEAT BALANCE DURING By-pass of one bank of LP2./3 (90% Load)