

SIMULATION MODEL IN TRNSYS OF A SMALL SUBSTATION FROM ROMANIA

Rodica FRUNZULICĂ¹, Andrei DAMIAN², Iolanda COLDA¹

The present paper refers to an energetically analysis for a small-scale modern substation, which supplies with thermal energy a block with 10 floors and 32 flats, situated in Bucharest. A comparison between energy consumptions for the “constant speed” case and the “variable speed” cases was also made. Three simulation scenarios have been taken into account: constant or variable speed of the heating pump, constant or variable indoor temperatures and different meteorological periods during the winter time. The simulations were obtained with the help of performant computer software TRNSYS and the results could be validated in the next heating season and also with the measured parameters in the modernized substation.

Keywords: TRNSYS, small-scale substation, variable speed, energy savings.

1. Introduction

The justification of the present research subject consist in some exploitation deficiencies that were noticed in district heating system from Bucharest, but also for other cities from Romania [1]. These deficiencies refer to several aspects:

- a. There are no possibilities to modify the functioning regimes of interior heating installations according to the real consumers' thermal energy demand. The heat demand for a building depends on various factors such as:
 - meteorological factors, with different and hazardous variations in time: outdoor temperature, wind, solar radiation [2],
 - “free” heat supply generated by the presence of occupants inside rooms, due to the electrical equipment, furnaces, lighting installations,
 - intervention of the building occupants in order to modify the indoor temperature according to the occupation degree, daily program or weekend,
- b. there are no possibilities to establish the correct costs for the consumed energy;
- c. at present, in most cases, the water supply flow comes from the district heating network, that means high electrical energy consumption to pump the fluid.

In order to improve the commissioning of the district heating systems and to correct the deficiencies that we mentioned beforehand, the present paper propose some experimental applications and possible measures in the building, such as [1]:

¹ Prof., Technical University of Civil Engineering Bucharest, Romania

² Assoc. Prof., Technical University of Civil Engineering Bucharest, Romania

1. Implementation of thermostatic valves for each terminal unit. Each thermostatic valve will modify the fluid mass inside the terminal unit, which will be reflected in the variation of the emitted heat in the room.
2. Each radiator will be equipped with an individual Heat Cost Allocator (HCA). That offers the possibility to establish the correct cost for the consumed thermal energy [3].
3. The implementation on the secondary circuit in the experimental substation of a variable speed pump, in order to adjust the total fluid flow corresponding to the action of thermostatic valves.
4. Tracking the substation functioning during the whole heating season.

Further fundamental premises for the rehabilitation measures and functioning regimes rationing, where considered [4]:

- Existing heat cost allocators on secondary circuits of the substation, for hot water and heating processes, for each block of flats,
- Existing heat meters on primary circuit of the substation,
- Existing water meters for hot and cold water at each sanitary object, which gives the advantage of correct bills for consumers, according to their individual consumptions. In addition, this will lead to a more careful behavior for hot and cold water utilization, in order to control their consumption, to retrieve and improve the technical state of their equipment and water installations.

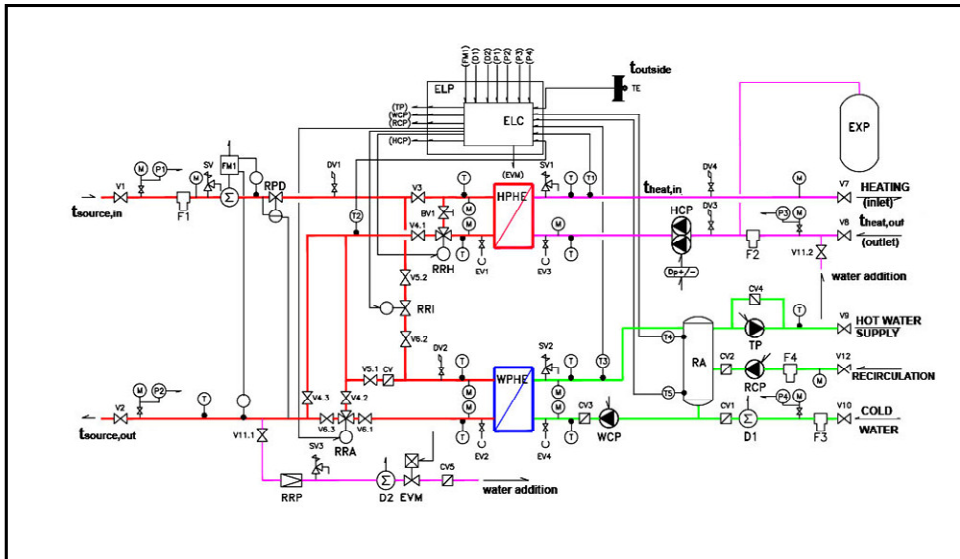

Fig.1: Detailed operation scheme of the small-scale substation

In order to accentuate the rehabilitation effects and their quantifications a comparison between 2 “witness” buildings (M_1 and M_2), in Bucharest was

accomplished. One of the risers of the block was kept in the old state, without any rehabilitation and the other one was rehabilitated and it functioned with a modern substation, as we mentioned before. To achieve this task, a simulation with the TRNSYS programming environment was performed (fig.1).

2. Problem formulation

Starting from the analysis of all equipment inside the experimental substation, a detailed operation scheme was traced (fig. 1). Primary and secondary circuits can be observed (one for heating process and the other for hot water supply). The regulation and control equipment which allow maintaining or varying some interest parameters according to heat delivery diagram from fig. 2.

This diagram make a correlation between outdoor temperature variations (t_{outside}) and the supply fluid temperatures inlet temperature on primary circuit ($t_{\text{source,in_set}}$), outlet fluid temperature on primary circuit ($t_{\text{source,out_set}}$), inlet temperature on secondary circuit for heating process ($t_{\text{heat,in_set}}$) and outlet fluid temperature ($t_{\text{heat,out_set}}$).

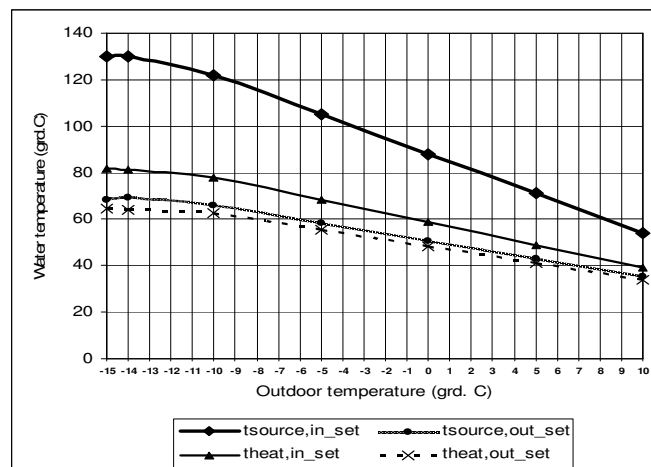

Fig. 2: Heat delivery diagram of the small scale substation

2.1 Description of the studied building and its installations

The block riser studied for the energetically analysis has 10 floors, a bowel and a technical floor. The exterior walls are made of full brick ($\lambda=0,8$ W/mK), 30 cm thick, rendered on both sides with cement mortar without any thermal insulation. The windows are double, with wooden frame and having reduced air permeability. The floor under the unheated bowel is made of 25 cm reinforced concrete, plated with cement mortar with a thickness of 3 cm. The last floor from the 10th level of the building is 34 cm thick and has a global transfer coefficient

of $0,606 \text{ W/m}^2\text{K}$ (well insulated). Most of the radiators are cast iron made, with high thermal inertia and variable number of elements according to each room demand. The total installed load ($P_{\text{heat,inst}}$) of all the radiators is 265153 W , a value much bigger than the theoretical load required by the Romanian design standard SR 1907/1,2-1997 assuming the stationary heating regime ($P_{\text{heat,req}} = 178\,784 \text{ W}$).

According to initial proposal, all the radiators were equipped with thermostatic valves and individual heat cost allocators, thus permitting to consumers to control indoor temperatures as function of their metabolic comfort and financial availabilities. A typical diagram for the thermostatic valves regulation is very difficult to establish taking into consideration each of the 44 apartments, thus the simulations were effectuated considering average indoor temperatures for the entire building, as a result of the thermostatic valve intervention. Hot water supply installations for the considered building are designed in order to insure the mass flows and pressures necessary for hot water consumers. The conception of the installations is with vertical risers and lower radial distribution [5]. The daily mass flow, calculated taking into consideration all utilization taps, is $11,88 \text{ m}^3/\text{day}$ with a maximum of $15,44 \text{ m}^3/\text{day}$.

2.2 Description of the heat supplying source and of the modern small-scale substation

Heat supplying source for the substation which delivers heat and hot water for considered building is a cogeneration source from South-Bucharest. Theoretical regime from the conception project design is $150^\circ\text{C} / 80^\circ\text{C}$ on primary circuit and $95^\circ\text{C}/75^\circ\text{C}$ on secondary circuit. Nominal primary fluid mass flow equals to $3,25 \text{ m}^3/\text{h}$, delivered from South Bucharest cogeneration source. On the secondary circuit nominal mass flow is $11 \text{ m}^3/\text{h}$ and it is assured by a variable speed pump (HCP). The hydraulic functioning mode of the internal heating system (the secondary circuit) is characterized by variable mass flow. The control of heat supply for buildings becomes mixed (qualitative – quantitative), based on temperature regulation in the supply pipe relative to outdoor temperature variation and to the local adjustments of mass flow correlated with the rooms heat losses [6]. The speed adjustment is achieved through frequency converters. The electronic regularization mode consists in linear adjusting of the available pressure (pump head) between its nominal value H_n (corresponding to the maximum mass flow) and $\frac{1}{2} H_n$ (corresponding to zero mass flow).

The circulation pumps as well as all the other pumps inside the rehabilitated substation are WILO variable speed pumps. These values will be constantly adjusting to the secondary heating circuit variable flow, resulted from the intervention of thermostatic valves of the rooms. Temperature control on supply and return in the primary and secondary circuit, according to the diagram

from fig.1, is achieved through two three-way valves: RRH and RRA and a RRI two-way valve (insert valve), mounted on the primary circuit, and controlled with an ELC type electronic regulator (fig.2) according to the following effective measured temperatures:

- $t_{\text{heat,in}}$ for the RRH valve (by-passing a fraction of the primary flow that passes through HPHE) if $t_{\text{source,out}} > 55^{\circ}\text{C}$; in this case, RRI is completely closed and RRA completely open (on the way to WPHE);

- $t_{\text{in,WPHE}}$ – the supply inlet temperature in the WPHE heat exchanger for hot water supply, when $45^{\circ}\text{C} < t_{\text{source,out}} < 55^{\circ}\text{C}$; in this case the RRI insert valve opens, mixing the primary thermal agent flow coming from the heat exchanger HPHE with the $t_{\text{source,out}}$ temperature, with a fraction (by-pass) of the flow that comes from the heat source at the $t_{\text{source,in}}$ temperature, thus achieving a higher potential for preparing hot water supply in the WPHE heat exchanger [7];

- $t_{\text{in,WPHE}}$, when $t_{\text{source,out}} < 45^{\circ}\text{C}$; in this case the RRA valve closes completely (on the way to the WPHE heat exchanger), and the RRI insert valve opens (up to 100 %), in order to prepare hot water in the secondary circuit of WPHE at the required consumer parameters (55-60 °C). In conclusion, it can be stated that in the case of the studied substation two types of controls have been applied in order to obtain thermal and electric energy savings:

- Temperature control from the substation according to heat deliver diagram and the outdoor temperature, and

- A control of the nominal point (by reducing the pump head) at the HCP variable speed pump on the secondary heating circuit, related to the modification of the total mass flow in the heating system resulting from adjusting the thermostatic valves. Both aspects will be illustrated through the energy analysis to be presented in the following paragraph.

2.3 The algorithm model of the modernized small-scale substation

Based on the operating characteristics of the equipments that compose the modernized substation the general simulation model of this system has been built in the programming environment TRNSYS, connecting the substation with the consumers that it effectively supplies [8]. These consumers are placed in a 10 floors block of flats which also was built in TRNSYS, with the help of the building preprocessor TRNBuild. The simulation scheme made in TRNSYS for the thermal substation described in fig.2 is presented in fig.3. The composing elements have been built in TRNSYS, corresponding to the general operating scheme depicted in fig.2 and to the operating characteristics used to design and build the substation. All the TRNSYS calculation modules, as well as the links between them, are illustrated in the fig.3. It can be noticed on this figure the connections between the modules created in order to describe the composing

elements of the modernized substation, as well as the control elements for the liquid flow regulation.

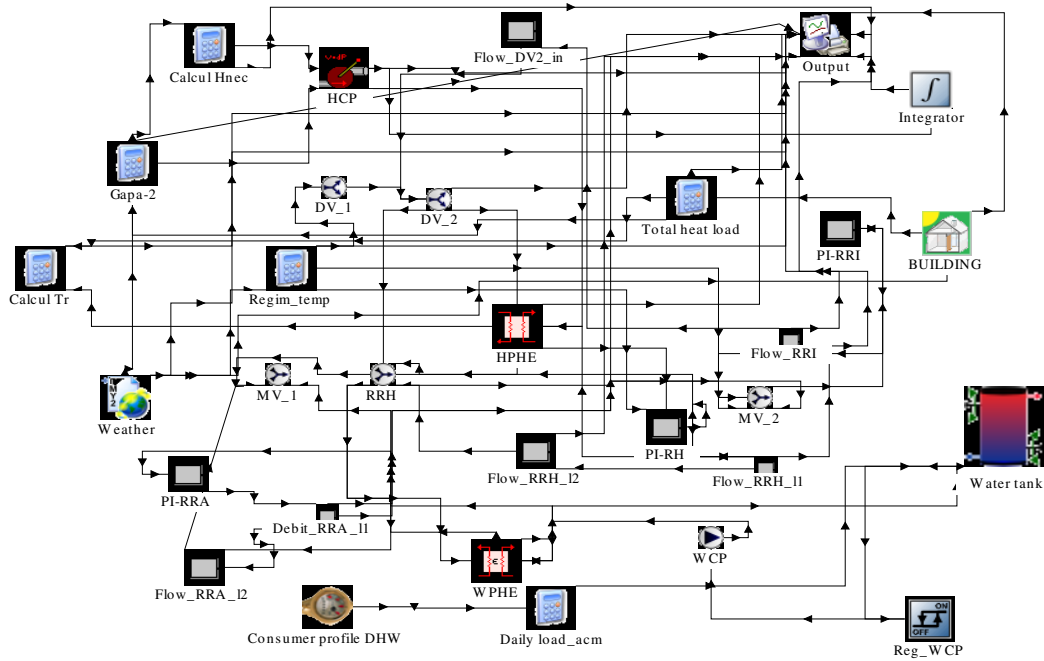

Fig.3: Overview of the TRNSYS simulation diagram for the small scale substation

The elementary object named "Weather" that appears in the left of the operating scheme contains all the weather data needed for the "BUILDING" module (for calculating the heat load and energy consumption for heating). This weather file of text type was taken from TRNSYS data base METEONORM, for the city of Bucharest, where the substation is situated.

3. Problem solution

In order to outline the energy savings due to the modernization of the small scale substation, we carried out a comparative analysis of energy consumptions for two main cases:

- A) using a Constant Speed (CS) pump HCP on the secondary heating circuit of the HPHE heat exchanger (see fig.1), and
- B) using a Variable Speed (VS) pump for the same heating circuit

In addition, both cases were associated with two sub-cases regarding the daily schedule of the mean indoor temperature assumed to be established in the building supplied with heat from the substation. Thus, the schedule 1 considered a mean constant temperature of 20 °C in the building over the daytime (continuous heat supply and best indoor comfort conditions assured by occupant's action on

thermostatic valves), while the schedule 2 considered a mean constant temperature of 20 °C over the night time (20h – 8h) and a lower temperature (18 °C) over the daytime (8h – 18h), when the occupants are supposed to be absent and close their thermostatic valves to save thermal energy.

Table 1

Total monthly electrical consumption $E_{\text{cons,HCP}}$ (in kJ)) by HCP pump for January

	Schedule 1 ($t_i = 20\text{ °C}$ 24h/24)	Schedule 2 ($t_i = 20\text{ °C}$ for 20h-8h and $t_i = 18\text{ °C}$ for 8h-20h)
Case A (Constant Speed)	10 690	9 856
Case B (Variable Speed)	8 523	6 776

Table 2

Total monthly electrical consumption $E_{\text{cons,HCP}}$ (in kJ) by HCP pump for March

	Schedule 1 ($t_i = 20\text{ °C}$ 24h/24)	Schedule 2 ($t_i = 20\text{ °C}$ for 20h-8h and $t_i = 18\text{ °C}$ for 8h-20h)
Case A (Constant Speed)	9 154	6 367
Case B (Variable Speed)	7 588	4 585

Table 3

Values of the total sensible heat demand $Q_{\text{sens,tot}}$ (in kJ) of the building simulated, for the two simulation periods

	Subcase A1 (Case A and schedule 1)	Subcase A2 (Case A and schedule 2)
January	$1,62 \cdot 10^8$	$1,5 \cdot 10^8$
March	$8,74 \cdot 10^7$	$7,63 \cdot 10^7$

In order to compare the energy savings between two different parts of the heating period, we have chosen two entire months: January (colder) and March (warmer), for what we performed TRNSYS simulations, taking into account the cases A and B, combined with the schedules 1 and 2. It resulted eight simulations to be performed, from what we choose to compare two main category of results:

- the fluid (hot water) temperatures on the secondary circuit obtained by simulation ($t_{\text{heat,in}}$ and $t_{\text{heat,out}}$) and the corresponding setpoint temperatures ($t_{\text{heat,in_set}}$ and $t_{\text{heat,out_set}}$) desired to be reached by the qualitative regulation (see fig.2);
- the electrical power (hourly values of $P_{\text{cons,HCP}}$, in kJ/h) consumed by the pump installed on the secondary heat circuit (HCP) in the cases A and B (constant speed-CS or variable speed-VS) and schedules 1 and 2 described previously, resulting by integration the total electrical energy consumed by the same pump ($E_{\text{cons,HCP}}$ in kJ) over one simulation month considering the same cases; in the table 1 are presented the results of $E_{\text{cons,HCP}}$ for January and in table 2 for March;

- the total sensible heat demand ($Q_{\text{sens,tot}}$) obtained by simulations, in the subcases A1 and A2 when considering the two different simulation periods, January and March; these heat demands should accord to the building thermal energy bill received by the administrator for the one-month period analysed – see table 3.

4. Conclusions

Some interesting conclusions after the overview of this simulation results are:

- the use of a variable speed pump on the secondary heating circuit means, in each of the two analysis period, to an important relative reduction in the electrical energy consumed by the HCP pump;

- the occupant's behaviour is more precisely linked to their direct interest to reduce their monthly heating bills, which is shown by the reduction of the total heat demand observed in the table 3 when schedule 2 replaced schedule 1;

The final conclusion of this paper is that the use of a variable speed pump on the heating circuit, combined with a judicious occupant's behaviour regarding the use of thermostatic valves, mean to important electrical energy savings, as well as to reduction of heating bills.

Acknowledgements

The research project was financed by the National Ministry of Education, through MENER Department (the Romanian Department of Environment, Energy and Resources).

REFERENCES

- [1] *Improvement of heat use in order to obtain occupant's comfort under optimal economical conditions*, Research project no. 460/2004, Technical University of Civil Engineering Bucharest, Final report 2006.
- [2] R. Dehaussse, *Énergie des bâtiments*, vol 3, PYC Editions, 1989.
- [3] *Technical specifications of thermostatic valves* - Danfoss Catalogue, 2004.
- [4] J. Besse, F. Candas, P. Delpech, E. Denieuil, *Réglage des distributions de chauffage*, Les Editions Parisiennes, 1998, 128 p.
- [5] M. Rizzo, *Chauffage et production d'ECS au fuel*, Les Editions Parisiennes, 1989, 181 p.
- [6] V. Pyrkov, *Hydraulic balancing of Heating and Cooling Systems*, Ed. Ljubljana Danfoss, 2004, 231 p.
- [7] *Technical specifications of plate-heat exchangers*, Schmidt-Bretten GmbH catalogue, 2003.
- [8] *TRNSYS – TraNSient System Simulation Program*, University of Madison, Wisconsin 1975.