

POTASSIUM PERMANGANATE OXIDATION TREATMENT FOR THE POLYCYCLIC AROMATIC HYDROCARBONS CONTAMINATED SOILS

Lionel CHOPLIN¹, Gheorghe LĂZĂROIU², Cătălina Raluca MOCANU³

The experiment had two purposes: to determine the time required by the potassium permanganate solution to remove the PAHs from the soil and secondly, to establish the period of time in which the potassium permanganate outlet solution has the same concentration as the inlet solution.

Keywords: polycyclic aromatic hydrocarbons, PAH, potassium permanganate, column experiment, advanced oxidation

1. Introduction

Polycyclic aromatic hydrocarbons (PAHs) are a complex class of organic compounds containing two or more fused aromatic rings, and containing only carbon and hydrogen atoms. They have a relatively low solubility in water, but are highly lipophilic.

Most of the PAHs with low vapour pressure in the air are adsorbed on particles. PAHs are formed mainly as a result of pyrolytic processes, especially the incomplete combustion of organic materials during industrial and other human activities, such as processing of coal and crude oil, combustion of natural gas, vehicle traffic, as well as in natural processes such as carbonization [1].

Soils and groundwater contaminated with organic compounds, such as solvents and polycyclic aromatic hydrocarbons are often difficult to remediate. The standard technologies pump and treat at the surface, are expensive and to takes years to complete. The contaminants held within these zones are often not well accessed by standard pump and treat systems, thus prolonging the time required for remediation and increasing the costs of remediation. In situ chemical oxidation is a developing class of remediation technologies in which organic contaminants are degraded in place by oxidants delivered to the subsurface. In Situ Chemical Oxidation using KMnO_4 is an alternative approach for sites where the physical disruption of contaminated soils is not desirable, feasible, or

¹ Prof., École Nationale Supérieure des Industries Chimiques de Nancy, France

² Prof., Department of Energy Production and Use, University "Politehnica" of Bucharest, Romania

³ PhD Student, Hydraulics & Hydraulic Machinery Dept, University "Politehnica" of Bucharest

necessary. Oxidant injection without extraction is feasible; however, extraction provides enhanced control of the subsequent movement of the oxidant after its release [3].

The column experiments described in the following paragraphs were conducted at the Laboratory of Chemical Engineering Science, CNRS-ENSIC-INPL, Nancy, France, under the guidance of Prof. Dr. Marie-Odile Simonnot. Their purpose was to determine the time required for a KMnO_4 solution to remove the PAH contained in a soil sample and the period of time needed for the outlet KMnO_4 solution to equal the inlet solution concentration.

2. Soil column experiment using continuous KMnO_4 solution flow

⇒ Purpose:

The purpose of this experiment is to determine the time needed for a KMnO_4 solution to remove the PAH contained in a soil sample; the soil sample came from an old crockery industrial site, found at Homécourt, in the north of the Meurthe et Moselle French department.

⇒ Soil initial characteristics:

Table 1

Homecourt soil initial properties	
Characteristic	Value
Argyle g/kg	96
Small sand g/kg	175
Azoth total g/kg	2,16
Organic material g/kg	171
pHwater	9,69
PAH compound	(mg kg ⁻¹ of dried soil)
Naphthalene	-
Acenaphthylene	-
Acenaphthene	490,2±56,3
Fluorene	59,6±6,5
Phenanthrene	331,8±4,5
Anthracene	129,2±15,9
Fluoranthene	664,4±34,6
Pyrene	370,9±116,6
Benzo(a)anthracene	277,2±3,2
Chrysene	221,2±12,6
Benzo(b)fluoranthene	136,0±14,1
Benzo(k)fluoranthene	8,7±0,2
Benzo(a)pyrene	141,7±9,2
Indeno(1,2,3-c-d)pyrene	65,9±6,9

Dibenzo(a,h)anthracene	64,4±2,1
Benzo(g,h,i)perylene	303,5±37,2
Sum of US EPA 16 PAHs	3264,0

⇒ **Potassium permanganate oxidation treatment for the polycyclic aromatic hydrocarbons contaminated soils:**

Installation components:

The following laboratory equipments were used to form a closed circuit: A Gilson Minipuls II Peristaltic Pump, Bioblock magnetic stirrer, Amersham Biotech Pharmacia XK 16 thermo stated glass column, Thermometer, Flowing tubes. Supplementary laboratory equipments were used to evaluate the results of the experiment: Behrotest SMA6 extraction system, Hitachi U-2000 Spectrophotometer, Buchi R110 Rotavapor, Bio-Tek Instruments HPLC Unit

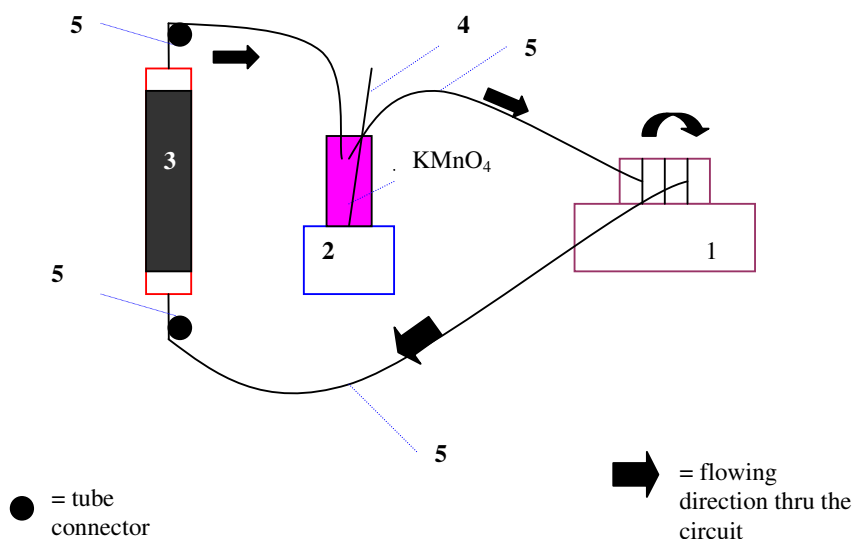

Fig. 1. The closed circuit used during the experiment.

Experiment description:

The solution used for the PAH contaminated soil chemical oxidation had a concentration of 12g/l and a volume of 500ml. The column was then placed in a vertical position using a support stand and connected to the rest of the circuit. To saturate the soil found inside the column, a flow rate of 0.2 ml/min of the 12g/l solution of KMnO₄ was assured by the peristaltic pump, for a period of 81 minutes (time counted since the soil inside became visibly wet and the moment when the first drop of liquid passed thru the column superior tube).

In order to maintain a continuous concentration of the KMnO_4 solution thru the circuit, the magnetic stirrer was used periodically for a period of 1-3 minutes, enough to assure the homogeneity and not to heat the solution.

The temperature of the solution was measured at the start of the experience (start of the column's saturation), the end of the saturation and right before the samples were taken. A thermometer was held in permanent contact with the KMnO_4 solution.

After the soil was saturated, the temperature of the KMnO_4 solution was measured and the flow rate was increased to 5 ml/min. 100 μl samples of the KMnO_4 solution were taken at regular periods of time, diluted in 100 ml of deionised water and submitted to the UV spectrophotometer analysis. The concentration of some of these samples is given in Table 2, found below.

Table 2

Prelevated samples characteristics				
Time between the sample taking (min)	Optical Density	Concentration of the KMnO_4 solution sample (g/l)	Temperature of the KMnO_4 solution at the moment of the sample taking ($^{\circ}\text{C}$)	Day
0	0,181	0,07548271	23,6	1
110	0,172	0,07172943	24,5	
131	0,172	0,07172943	24,5	
146	0,166	0,06922724	25	
165	0,168	0,0700613	25	
523	0,147	0,08862362	24,8	
563	0,147	0,08862362	24,8	
1358	0,148	0,05553471	19,5	
1388	0,147	0,05515947	19,7	
1418	0,147	0,05515947	19,8	
1448	0,148	0,05553471	19,9	
1493	0,148	0,05553471	20	
1583	0,146	0,05478424	20	
1628	0,146	0,05478424	20	
1778	0,142	0,0532833	20	

Extraction and analysis:

The soil was removed from the column, air dried and then submitted to a nine hours Soxhlet extraction (six samples, each of 0.5 g of soil, the solvent used being a mixture of dichloromethane and hexane in a 1:1 volume ratio). After the extraction, the organic solvent was separated using the rotary evaporator. In order to be analyzed by a HPLC unit, the samples need to be purified by passing thru a

column of silica gel, using as mobile phase a mixture of hexane and dichloromethane in a 9:1 volume ratio.

After purification, the liquid was submitted to a new evaporation and to a later dilution with 5 ml of acetonitrile. 2 ml of this mixture was poured in a standard screw-capped HPLC glass vial and submitted to the HPLC analysis.

The HPLC parameters used for the PAH identification were: ➤ Column used (Alltech Prosphere PAH 300A 5u 250 mm x 4.6 mm, Spec Range: 210 nm - 291 nm); ➤ Mobile phase (Gradient acetonitrile /water 49:51 % vol. ratio, Flow rate: 1.2 ml/min); ➤ Temperature (ambiental).

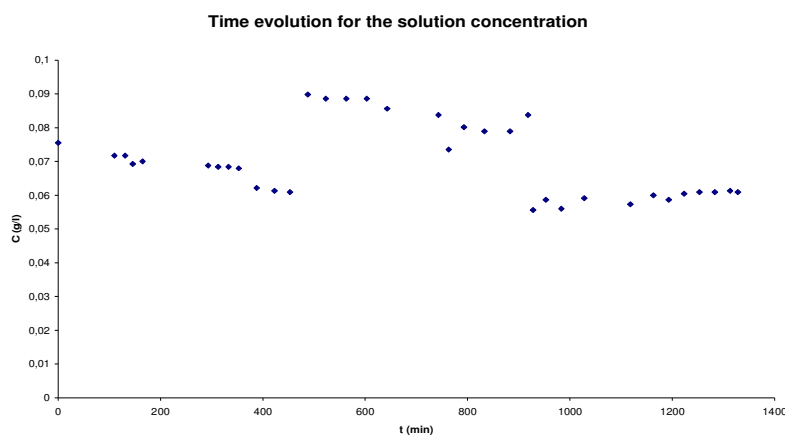

Fig. 2. Time evolution for the solution concentration.

Results:

Table 3

Soil PAH concentration values, before and after the KMnO₄ treatment

PAH compound	PAH Concentration in soil sample (mg/kg dw)		Number of PAH compound mols degraded during treatment (E^{-05})	EPA required concentration in soil sample (mg/kg dw)
	Before treatment	After treatment		
Naphthalene	-	-	Not the case	0,095
Acenaphthylene	-	-		0,25
Acenaphthene	490,2±56,3	Not found		0,015
Fluorene	59,6±6,5	4,14600551	1,07017	0,015
Phenanthrene	331,8±4,5	24,8159832	5,51092	0,080
Anthracene	129,2±15,9	12,1706767	2,10638	0,020
Fluoranthene	664,4±34,6	67,5319324	9,46306	0,080
Pyrene	370,9±116,6	43,5549525	5,1899	0,070

Benzo(a)anthracene	277,2±3,2	20,3872054	3,60794	0,020
Chrysene	221,2±12,6	18,5291005	2,84731	0,037
Benzo(b)fluoranthene	136,0±14,1	13,0704522	1,5627	0,020
Benzo(k)fluoranthene	8,7±0,2	9,1803653	0,0066	0,0070
Benzo(a)pyrene	141,7±9,2	10,597177	1,66665	0,010
Indeno(1,2,3-c-d)pyrene	65,9±6,9	Not found	Not the case	0,010
Dibenzo(a,h)anthracene	64,4±2,1	Not found		0,017
Benzo(g,h,i)perylene	303,5±37,2	Not found		0,034

3. Conclusions

The removal of certain quantities of PAH existing in the soil sample can be observed from the Table 3, found on top. Also, a change in color and odor of the soil sample could be observed: the color of the soil got lighter after the treatment and the odor became unperceivable by human nose.

As we can be seen from Table 3, the number of PAH mols degraded during our experiment is very low, having an order of 10^{-5} . The number of KMnO_4 mols consummated during treatment equals 0.0374 mol HMnO_4 . We can now draw the conclusion that 98.94% of the initial number of KMnO_4 were consummated for the degradation of 10^{-5} mols of the 16 EPA list PAH compounds, meaning the KMnO_4 also degraded PAH compounds besides the 16 found on the EPA list and part of the organic carbon found in soil.

Although the reaction time was achieved and more then that, exceeded by more then 10 times, the concentration of the outlet KMnO_4 solution didn't equalize the inlet concentration. Meaning the KMnO_4 solution needs more then 4000 minutes to totally oxidize the PAH compounds found in the soil sample, acting not only on these compounds but also oxidizing other organic compounds from the soil. An outlet concentration equal to the inlet concentration signifies a total removal of the PAH compounds from the soil sample and we can draw the conclusion that further experimental studies need to be conducted in order to determine the exact time needed for this total removal.

REFERENCES

- [1]. *World Health Organization, Regional Office for Europe Publication, Air Regulations-Chapter 5.9-Polycyclic Aromatic Hydrocarbons, Denmark, 2000.*
- [2]. *U.S. Department of Health and Human Services Publication, Toxicological profile for Polycyclic Aromatic Hydrocarbons, August 1995.*
- [3]. *U.S. Department of Energy, Office of Environmental Management, Office of Science and Technology, In Situ Chemical Oxidation using Potassium Permanganate, September 1999.*